

WORLDWIDE ELECTRIC CORPORATION
HdR SERIES PROGRAM - WORM GEAR SPEED REDUCERS
FLANGE INPUT - SHAFT OUTPUT - DIMENSIONS

MODEL # HdRF262-*-DE-56C

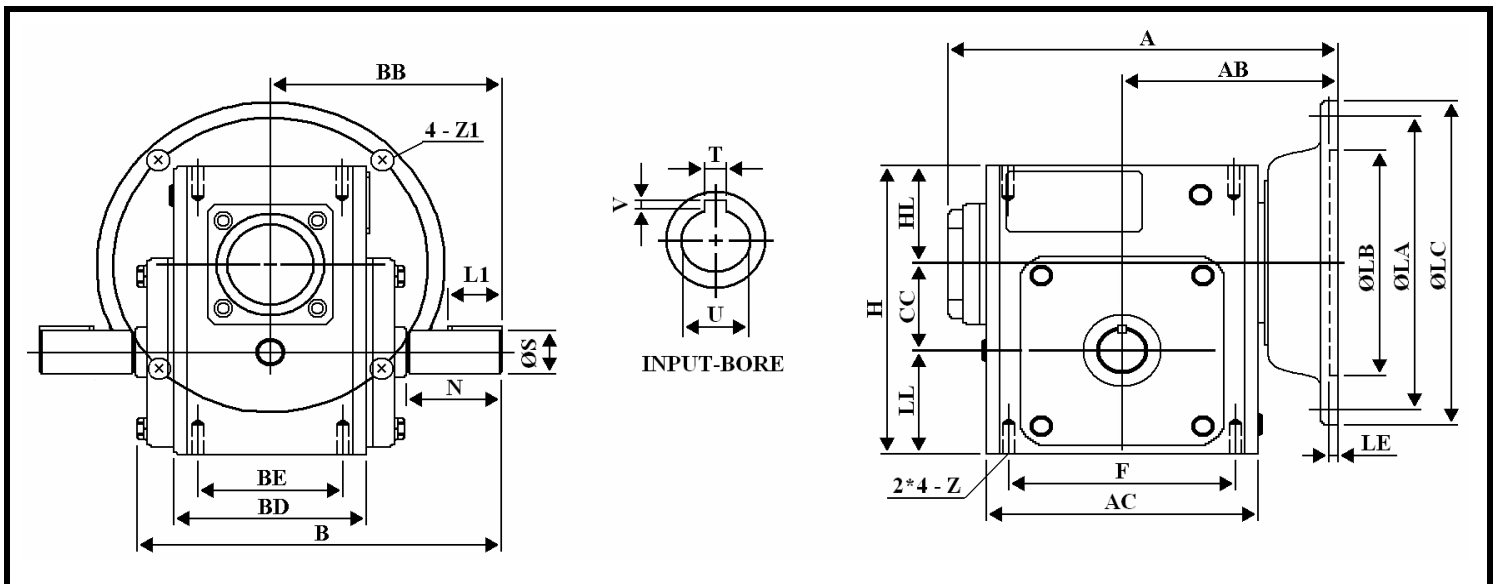
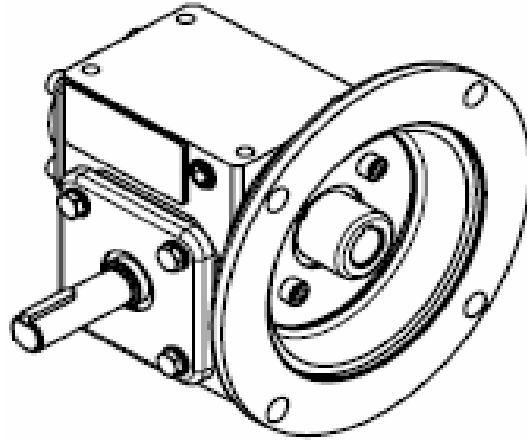

DOUBLE END OUTPUT - DIMENSIONS - Inches

Size	A	AB	AC	B	BB	BD	BE	CC	F	H	HL	LL	N	Z
262	9.41	5.059	7.165	8.872	5.63	4.685	3.375	2.625	6.375	8	2.437	2.938	2.626	3/8-16 UNC

Size	INPUT BORE		OUTPUT SHAFT			FLANGE					NEMA FRAME	OIL (OZ.)
	U	T*V	L1	S	W*Y	LA	LB	LC	LE	Z1		
262	0.625	3/16 * 3/32	2	1.125	1/4 * 1/8	5.875	4.5	6.496	0.157	0.433	56C	34.55

* Suitable For Any Ratio

